

### **Arizona Department of Transportation**

The largest consumer of wood products by state agencies is most likely Arizona Department of Transportation (ADOT). Bertha A. Whitby, Chief Procurement Officer for ADOT, has promised to compile a volume estimate for the number of wooden guardrail posts that are replaced each year. Specifications for the replacement and inspection of wooden guardrail posts, as stated by ADOT, are presented in Appendix A and B.

In researching procurement procedures on the Arizona State Procurement website ([spo.az.gov/](http://spo.az.gov/)), the means by which guardrail posts are replaced is done through an independent contractor and not ADOT. Apparently ADOT will award contracts to independent companies for the repair of guardrails, by district, i.e. Holbrook District, Prescott District. It is then up to the independent contractor to purchase guardrail materials that meet ADOT specifications (Appendix A and B).

### **Arizona Correctional Industries**

Arizona Correctional Industries (ACI) operates a custom wood working shop at the State Prison in Florence, AZ. The manager for the woodshop estimates that the shop annually purchases 100,000 board feet of mixed hardwood and pine lumber. As reported by the procurement agent for the woodshop, most of the wood materials are purchased by state contract through Phoenix based lumber wholesalers. The main two wholesalers to (ACI) are Lumber Products and Trio Forest Products. Hardwood species purchased by ACI include red oak, black walnut, and yellow poplar. The most common hardwood item purchased by ACI is kiln dried 6/4 (1.5 in.) thick red oak. This item is a fairly high market value item and as stated by the manager of the ACI woodshop, the client specifying the red oak also pays a premium for the finished item. The manager of the ACI woodshop also stated that at the Florence facility he can laminate veneer to medium density fiberboard substrates for fabrication of office desks. The pine item that ACI purchases most frequently is #2&Btr western spruce, pine, fir (SPF). It was not explicitly stated how the SPF is utilized and what products the material is manufactured into.

ACI is an organization identified by the Arizona Procurement code as a set aside company and thus all state governmental units are encouraged to allocate one percent of purchases or contracts to ACI, whenever possible. Other set aside organizations include Arizona Industries for the Blind and any certified nonprofit agency serving disabled individuals. Depending on the specifications for the custom orders received at ACI, ponderosa pine from Arizona should be a suitable material for some of ACI's projects. A restraining factor however is the limited kiln drying capacity in Arizona.

## **Yavapai Exceptional Industries**

Yavapai Exceptional Industries (YEI) is also a designated set aside company by the Arizona Procurement code. The primary lumber species that YEI purchases are redwood and clear pine. The redwood lumber is used in the construction of picnic tables and other wooden patio furniture. Clear pine is also used in the fabrication of the patio furniture. In addition to outdoor furniture, YEI also manufactures wood packaging boxes and survey stakes. In speaking with the woodshop manager, ponderosa pine would be a species that would meet most of YEI's material specifications. However, the material would have to be kiln dried.

## **Arizona State Fair**

The Arizona State Fair annually purchases at least \$6,000 worth of wood shavings from a company in Canada. The State Fair has the authority to purchase up to \$50,000 worth of wood shavings annually. Canyon Country Mill & Resources in Fredonia, AZ would be able to supply the State Fair with wood shavings. It is not known if Canyon Country is registered with the Arizona Procurement Agency. The procurement contract is presented in Appendix C.

**ARIZONA DEPARTMENT OF TRANSPORTATION \* MATERIALS GROUP**

1221 NORTH 21ST AVENUE PHOENIX, ARIZONA 85009-3740 PHONE (602) 712 - 7231

**POLICY AND PROCEDURE DIRECTIVE**

 James P. Delton  
 Assistant State Engineer

TO: ALL MANUAL HOLDERS	PPD NO. 9
SUBJECT:  GUIDELINES FOR INSPECTION AND ACCEPTANCE OF TIMBER GUARDRAIL POSTS AND BLOCKS	EFFECTIVE DATE:  February 27, 2009

**1. GENERAL**

1.1 This Policy and Procedure Directive supersedes P.P.D. No. 02-01.

1.2 The purpose of this directive is to provide guidelines in the inspection and acceptance of timber guardrail posts and blocks, which ensure a product with proper preservation treatment, adequate strength, and good appearance.

1.3 Solid timber posts and blocks may be either rough sawn (unsurfaced) or S4S (surfaced four sides) lumber.

1.4 Glued laminated timber shall be constructed according to the requirements of ANSI/AITC (American National Standards Institute/American Institute of Timber Construction). The manufacturing plant for glued laminated timber shall be certified and licensed by AITC. The manufacturer of glue laminated timber posts shall brand the tension face of the post in an area which will be above the ground line and below the bottom of the block. Laminated posts shall be installed with the tension face of the post facing the roadway.

**2. APPLICABLE DOCUMENTS**

- 2.1 ADOT Standard Specifications, Section 1012
- 2.2 American Wood Preservers Association (AWPA)
- 2.3 Western Wood Products Association (WWPA)
- 2.4 AASHTO M 133, and M 168
- 2.5 ASTM D 2559
- 2.6 American National Standards Institute (ANSI)
- 2.7 American Institute of Timber Construction (AITC) 113
- 2.8 ANSI/AITC A 190.1
- 2.9 International Conference of Building Officials, Evaluation Service (ICBO ES)

### **3. CLASSIFICATION**

#### **3.1 Solid Timber Posts and Blocks:**

3.1.1 Solid timber, rough sawn shall be graded in accordance with WWPA Grading Rules, Section 80.00 for Post and Timbers, No. 1 or better.

3.1.2 Solid timber, S4S shall be graded in accordance with WWPA Grading Rules, Section 80.00 for Post and Timbers, No. 1 or better.

#### **3.2 Glue Laminated Timber Posts and Blocks:**

3.2.1 Lumber used for glue laminated timber guard rail posts and blocks shall conform to WWPA Grading Rules, Section 62.00, Structural Joists and Planks, No. 1 or better S4S lumber.

3.2.2 Adhesive used to bond laminated wood products shall be a two-component system that complies with ASTM D 2559 and has passed the ICBO ES, Acceptance Criteria for Exterior Sandwich Panel Adhesives (AC05).

3.2.3 Laminated posts and blocks shall be glued together in a face-to-face glue joining, conforming to the requirements of AITC standards.

3.3 The required posts and blocks sizes shown in the contract documents shall be understood to be nominal dimensions. Allowable tolerances are shown in Subsection 5.5, Field Inspection.

### **4. WOOD PRESERVATION TREATMENT & FABRICATION**

4.1 Drilling or fabrication should be done where possible before preservation treatment process. In event of a mechanical injury or field cutting, field treatment should be in accordance with AWPA Standard M2.

4.2 The treatment process, including seasoning shall be in accordance with the requirements of AASHTO M 133, and AWPA C1, C2, and C28.

4.3 The inspection at the wood preservation plant for posts and blocks shall conform to the requirements of AWPA M2.

4.4 The Materials Central Laboratory or the Regional Materials Laboratory nearest to the treatment plant may conduct the inspections at wood preservation plants or fabrication facilities within the state. For wood preservation plants or fabrication facilities outside the state, an approved consulting inspection service may be engaged.

4.5 A quality check on the certification procedure for the treatment of posts and blocks, a spot check type of inspection of the wood preservation plant facilities, will be periodically performed. This will include observing the conditioning process, checking the residual moisture before treatment, checking sampling and testing preservative agents, and checking assay procedures.

## **5. FIELD INSPECTION**

5.1 The responsibility for acceptance of the posts and blocks will be that of the Engineer on the Project. Certification by the wood preservation plant will not substitute for the inspection for "Grade of Lumber".

5.2 A copy of the certification for preservation treatment and stress grade, together with the treatment assay sheet is to accompany each shipment of posts and blocks.

5.3 The contractor shall submit to the Engineer a Certificate of Compliance conforming to the requirements of the ADOT Standard Specifications Subsection 106.05. The certificate shall be furnished by the post and block supplier and shall also include the following information: (a) Identification of the qualified inspection and testing agency, (b) the species or species group of lumber as well as the grade, and (c) identification of the recognized standard to be used as an acceptance basis for this product.

5.4 Unloading, handling, and job site storage procedures:

5.4.1 Cable slings or chokers should not be used to handle post and block materials unless adequate blocking is provided between the cable and the wood member. Protection cleats or blocking shall be applied at pick-up points to protect corners. A level storage area is required to avoid warping. Wood members shall be supported with blocking so spaced as to provide uniform and adequate support. Stored wood members shall have the top and all of the sides covered with a moisture resistant covering.

5.5 Allowable dimensional tolerances for posts and blocks:

5.5.1 Dimensional tolerances for solid timber rough sawn posts and blocks shall be plus or minus 1/16 inch in thickness and width; and plus or minus 1/8 inch in length.

5.5.2 Dimensional tolerances for solid timber (S4S) posts and blocks shall be plus or minus 1/2 inch in thickness and width; and plus or minus 1/8 inch in length.

- 5.5.3 The standard dimensions for glue laminated posts and blocks (S4S) with a nominal dimension of 6 inches x 8 inches shall be finished to the dimensions of 5-1/2 inches x 7-1/2 inches, according to AITC 113. Dimensional tolerances for glue laminated lumber posts and blocks shall be plus or minus 1/16 inch in thickness and width; and plus or minus 1/8 inch in length.

5.6 The following are guidelines for inspection of appearance and physical characteristics for grade. Definitions, characteristics, and the maximum allowable values are listed below for solid timber and glue laminated posts and blocks. See WWPA Section 80.00 for additional information for solid timber posts and blocks. See WWPA Section 62.00 for additional information for lumber used in glue laminated posts and blocks.

- 5.6.1 **Grain** – *The fibers in wood and their direction, size, arrangement, or quality.* A medium grain is required, which means an average of 4 or more annual rings per inch measured on a line perpendicular to the rings. See Attachment #1 and WWPA Section 170.00 for additional information.

*Slope of grain is the deviation of the wood fiber from a line parallel to the edges of the piece.* A maximum deviation of 1 in 10 is allowable. See Attachment #2, WWPA Section 230.00, and WWPA Section 712.00 for additional information.

- 5.6.2 **Sapwood** – *The outer layers of growth between the bark and the heartwood which contain the sap.* For further explanation see WWPA Section 738.00.

- 5.6.3 **Heartwood** – *The inner core of the tree trunk comprising the annual rings containing nonliving elements.* In some species, heartwood has a prominent color different from the sapwood. For further explanation see WWPA Section 714.00.

- 5.6.4 **Splits** – *A separation of the wood through the piece to the opposite surface or to an adjoining surface due to the tearing apart of the wood cells.* A split which extends into the piece on a plane parallel to the bolthole shall not be accepted. See Attachment #1.

For solid timber guard rail posts and blocks, the length of a split shall not exceed the width of the piece. Splits equal in length to the width of the piece, or equivalent to the total length of end checks, are permissible. See Attachments #1 and #2.

For lumber used for glue laminated posts and blocks, splits equal in length to the width of the piece are permissible. For further explanation see WWSA Section 742.00.

- 5.6.5 **Checks** – *A separation of the wood normally occurring across or through the rings of annual growth and usually as a result of seasoning. Checks are measured as the penetration perpendicular to the widest face. Where two or more checks appear on the same face, only the deepest one is measured. Where two checks are directly opposite each other, the sum of their depths are taken.*

For solid timber posts and blocks, checks are allowed to be a maximum of 1/2 the thickness of the post or block for single checks, or for checks opposite each other the sum of their depths is allowed to be a maximum of 1/2 the thickness of the post or block. See Attachment #1.

Checks in glue laminated timber guard rail posts and blocks may appear as openings parallel to the grain on the sides of the members, (See Attachments #1, #2, and #3). Surface seasoning checks are not limited. Checks which are located outside the shear critical zone (See Attachment #4) and which run in the direction of the length of the post are permitted to be a maximum of 3/16 inch in width and have a depth of not greater than 1/3 of the width of the laminated member. Allowable checks in the shear critical zone are determined by the equations shown in Attachment #4 [ $d_{\text{allowable}} = 0.1W$ ] and [ $l_{\text{allowable}} = 0.9W$ ], but  $l_{\text{allowable}}$  shall not be greater than 6 inches]. The length ( $l$ ) of side checks is not restricted. Through checks at ends are limited as for splits, see Attachment #1.

- 5.6.5 **Holes** – *Holes may either extend partially or wholly through the piece. An alternate designation for holes, which extend only partially through the piece, is surface pits. Limitations shown below do not include holes drilled for hardware.*

For solid timber guard rail posts and blocks, holes shall be limited to pin hole sizes. A pinhole is defined as not being over 1/16 inch in diameter.

Holes in lumber for glue laminated posts and blocks from any cause shall be limited to a maximum of 1-1/4 inches, and are further limited to one hole of a maximum of 1-1/4 inches, or equivalent smaller holes, for each 3 linear feet. For further explanation see WWSA Section 716.00.

- 5.6.6 **Skips** – *Skips are areas on a piece that failed to surface clean.*

For solid timber guard rail posts and blocks, occasional skips up to 1/8 inch in depth and two feet in length are allowable.

Hit-and-miss skips in lumber for glue laminated guard rail posts and blocks are allowed in a maximum of 10% of the pieces. Hit-and-miss skips are defined as skips which are a series of skips not over 1/16 of an inch deep with surfaced areas between.

- 5.6.7 **Wane** – *Bark or lack of wood from any cause, except eased edges, on the edge or corner of a piece of lumber.*

For solid timber guard rail posts and blocks, wane which is 1/4, or equivalent, of any face is allowed.

For lumber used in glue laminated guard rail posts and blocks, the allowable wane is 1/4, or equivalent, of the full length of the thickness face and 1/4, or equivalent, of the full length of the width face, provided that wane does not exceed 1/2 the thickness or 1/3 the width for up to 1/4 the length. For further explanation see WWPA Section 750.00.

- 5.6.8 **Shake** – *A lengthwise separation of the wood, which occurs between or through the rings of annual growth.*

For solid timber guard rail posts and blocks, shake of up to 1/3 the thickness is allowed, see Attachment #1.

For lumber used in glue laminated guard rail posts and blocks, through shakes at ends are limited as for splits. Surface shakes up to two feet in length are allowed, see Attachments #1, #2, and #3. For further explanation see WWPA Section 740.00.

- 5.6.9 **Knots** – *A portion of a branch or limb that has become incorporated in a piece of lumber.* Knots, which are sound and tight, and well spaced, are permitted. A sound knot contains no decay. A tight knot is so fixed by growth, shape or position that it retains its place in the piece.

For solid timber guard rail posts and blocks, the knot size limitation on a nominal 6-inch face is 1-7/8 inches, while on an 8-inch face the knot size is limited to 2-1/2 inches. See Attachment #1.

For lumber used in glue laminated guard rail posts and blocks, knots at the edge of the wide face for a nominal width face of 6 inches are limited to 1-1/2 inches. Knots at the centerline of the wide face for a nominal width face of 6 inches are limited to 2-1/4 inches.

5.7 Measurement of Characteristics

5.7.1 Grain, checks, holes, skips, wane, knots, and shake may be measured with a tape measure or similar device subdivided to at least 1/16 of an inch. Grain and shake are measured on the ends of the posts and blocks. Checks are most often found on the ends, but may also occur on the sides or faces. Splits and checks are measured for an average depth, or penetration, into the piece. A thin metal spatula or similar blade at least six inches in length may be used for this determination. The blade should be inserted firmly, but not forced into each split or check.



---

James P. Delton, P.E.  
Assistant State Engineer  
Materials Group

Attachments (4)

KNOTS

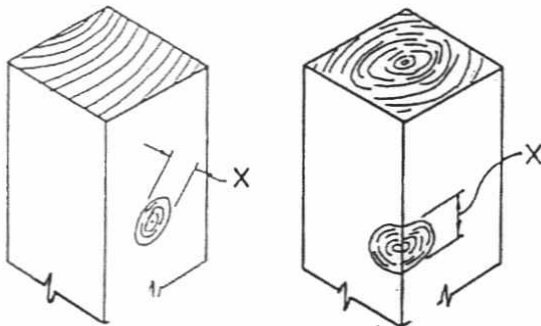

X — Measure the least dimension

SHAKES

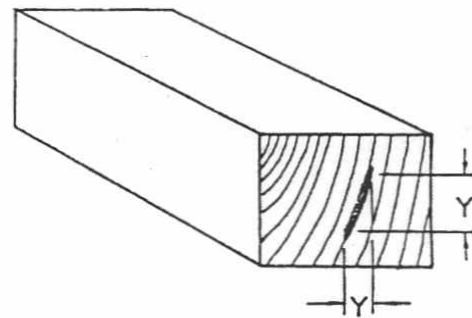

Y — Whichever is the least dimension

CHECKS

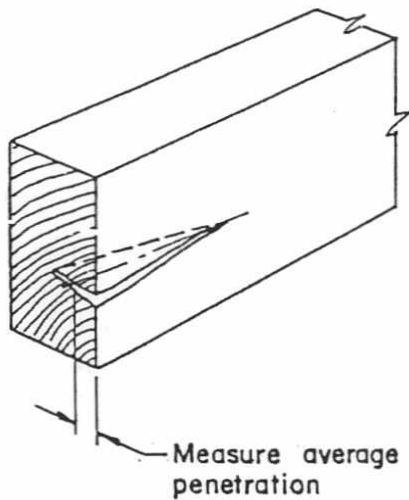

SPLITS

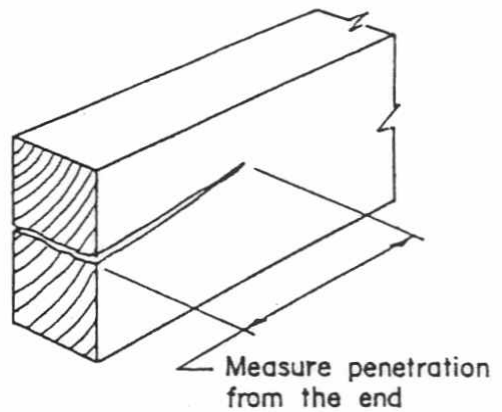

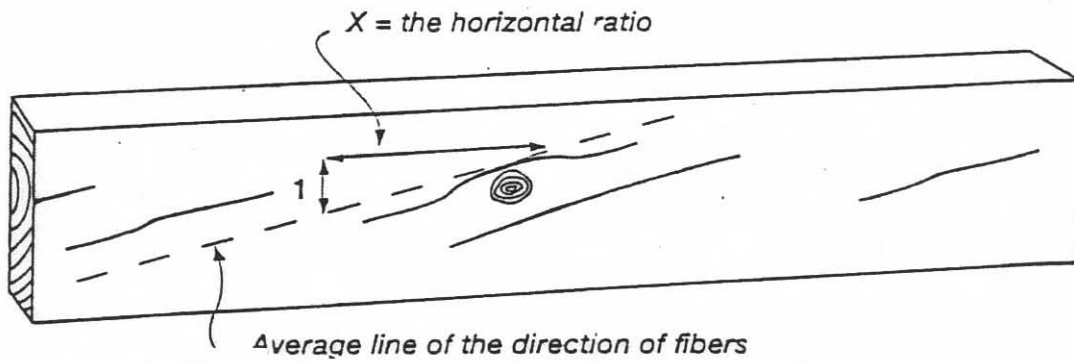
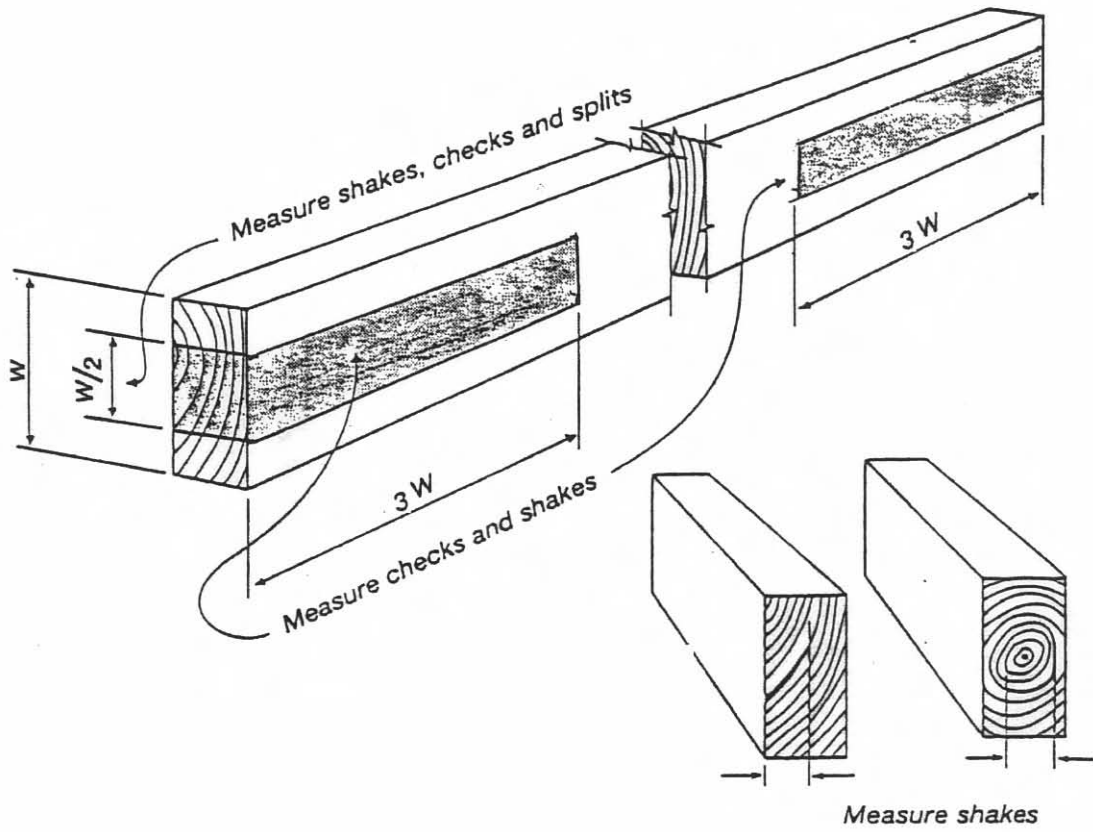

February 27, 2009

P.P.D. No. 9 (Attachment #3)

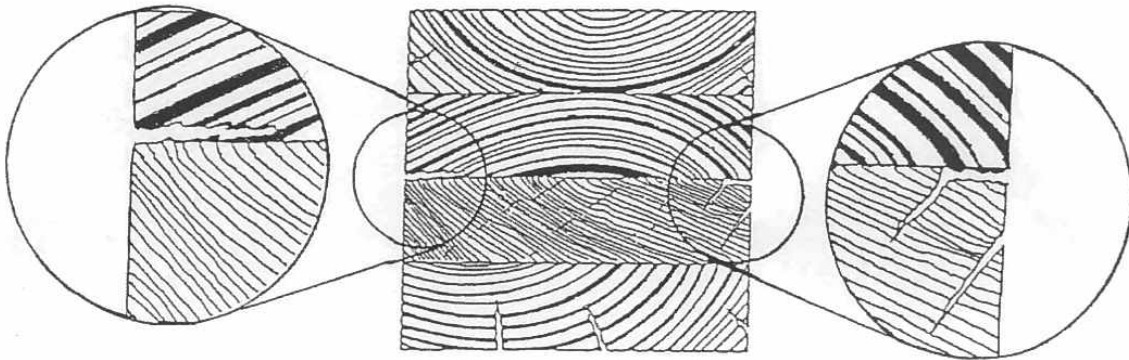

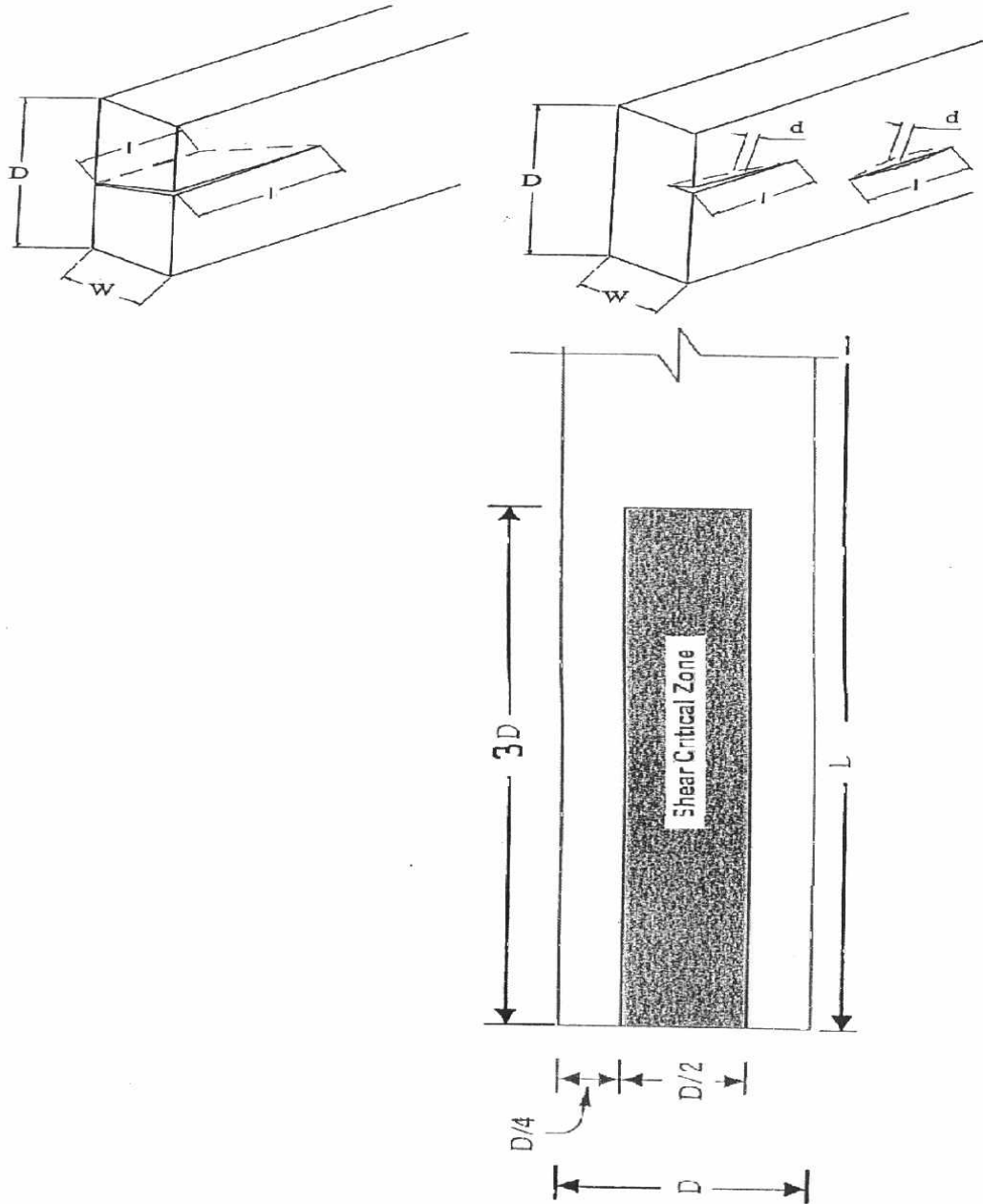

"d" allowable =  $0.1 W$

"l" allowable =  $0.9W$

$L$  = length of the post above the surface



<b>TABLE 1012-2 GUARDRAIL FASTENERS</b>		
<b>Part Name</b>	<b>ARTBA Drawing No.</b>	<b>AASHTO M 180 Designation</b>
W-Beam	RE - 3	Class A, Type 1
W-Beam Back-Up Plate	RE - 4	Class A, Type 1
W-Beam Terminal Connector	RE - 8	Class A, Type 1
Rub Rail	RE - 9	
Thrie Beam	RE - 63	Class A, Type 1
Thrie Beam Back-Up Plate	RE - 64	Class A, Type 1
Anchor Plate	RE - 71	

<b>TABLE 1012-3 METAL GUARDRAIL POSTS AND BLOCKS</b>		
<b>Part Name</b>	<b>ARTBA Drawing No.</b>	<b>Specification</b>
G4 and MB4 Structural Shape Post and Block	P - 10	
G4 and MB4 Bent Plate Post and Block (Steel)	P - 52	ASTM A 570, Grade 40
G9 and MB9 Structural Shape Post and Block	P - 54	
G9 and MB9 Bent Plate Post and Block (Steel)	P - 56	ASTM A 570, Grade 40
Terminal Post (Steel)	P - 60	ASTM A 500, Grade B
Terminal Post Foundation Plates (Steel)	P - 61	

**1012-4 Timber Guardrail, Posts and Blocks:**

Timber for posts and blocks shall be rough sawn (unplaned) or S4S with the nominal dimensions indicated. Any species or group of woods graded in accordance with the requirements for Timber and Posts of the Western Wood Products Association may be used.

Timber shall be No. 1 or better, and the stress grade shall be as follows:

6 inch by 8 inch Post and Block	1,200 psi
8 inch by 8 inch Post and Block	900 psi
10 inch by 10 inch Post and Block	900 psi

When the plans show guardrail systems using eight-inch by eight-inch timber posts and blocks, the contractor may use 8-1/4 inch by 8-1/4 inch nominal size posts and blocks with a stress grade of 825 pounds per square inch.

At the time of installation, the dimensions of timber posts and blocks shall vary no more than  $\pm 1/2$  inch from the nominal dimensions as hereinbefore specified.

The size tolerance of rough sawn blocks in the direction of the bolt holes shall vary no more than  $\pm 3/8$  inch. Only one type of post and block shall be used for any one continuous length of guardrail.

All timber shall have a preservative treatment in accordance with the requirements of AASHTO M 133.

## **SECTION 1013 BEARING PADS:**

### **1013-1 Preformed Fabric Pads:**

Preformed fabric pads shall be composed of multiple layers of eight-ounce cotton duck impregnated and bound with high quality natural rubber or of equivalent and equally suitable materials compressed into resilient pads of uniform thickness. The number of plies shall be such as to produce the specified thickness, after compression and vulcanizing. The finished pads shall withstand compression loads perpendicular to the plane of the laminations of not less than 10,000 pounds per square inch without detrimental reduction in thickness or extrusion.

Preformed fabric pad samples will be tested by the Department.

The manufacturer certification and sampling shall conform to the requirements of Subsection 1013-3.

### **1013-2 Elastomeric Bearing Pads:**

#### **1013-2.01 General:**

The work shall consist of furnishing and installing elastomeric bearing pads. Bearings shall be constructed in accordance with the details shown on the plans and as specified in these specifications.

Prior to shipment from the point of manufacture, bearings shall be packaged in such manner to ensure that during shipment and storage the bearings will be protected against damage from handling, weather, or any normal hazard. All bearings shall be stored at the work site in an area that provides protection from environmental and physical damage. When installed, bearings shall be clean and free of all foreign substances.

Bearings shall be installed to the positions and orientations shown on the plans. Bearings shall be set level, in exact positions, and must have full and even bearing on all bearing planes. Bearings surfaces located at improper elevations or set not level and true to plane shall be corrected prior to placement of bearings. Elastomeric bearing pads shall be set directly on properly prepared concrete surfaces without bedding material.

## Appendix C



## Master Blanket Purchase Order AESF12-009656

## Header Information

<b>Purchase Order Number:</b>	AESF12-009656	<b>Release Number:</b>	0	<b>Short Description:</b>	Wood Shavings (Bedding)
<b>Status:</b>	3PS - Sent	<b>Purchaser:</b>	Jack Bell	<b>Receipt Method:</b>	Quantity
<b>Fiscal Year:</b>	2012	<b>PO Type:</b>	Blanket	<b>Minor Status:</b>	
<b>Organization:</b>	Arizona Exposition & State Fair	<b>Location:</b>	44LF - Entries Livestock - Fair	<b>Type Code:</b>	
<b>Department:</b>	44L - Entries - Livestock	<b>Entered Date:</b>	08/01/2011 11:12:50 AM	<b>Control Code:</b>	
<b>Alternate ID:</b>		<b>Retainage %:</b>	0.00%	<b>Discount %:</b>	0.00%
<b>Print Dest Detail:</b>	If Different	<b>Release Type:</b>	Direct Release	<b>Pcard Enabled:</b>	No
<b>Catalog ID:</b>		<b>Tax Rate:</b>		<b>Actual Cost:</b>	\$6,025.50
<b>Contact Instructions:</b>	Driver to call Security when on site for delivery assistance				
<b>Master Blanket/Contract End Date (Maximum):</b>	08/31/2013 05:00:00 PM				
<b>Project No.:</b>	UM09-003				
<b>Special Purchase Types:</b>	N/A				
<b>PIJ NUMBER:</b>					
<b>Attachments:</b>	<a href="#">UM09-003 Shavings Main Contract.pdf</a>				

## Primary Vendor Information &amp; PO Terms

<b>Vendor:</b>	<a href="#">000019327 - Norstar Industries Ltd.</a> Linda Pavelich 101 - 18146 105 Avenue Edmonton, AB T5S 2T4 CAN Email: lindap@norstarindustries.com Phone: 7804146085 FAX: 7804146082	<b>Payment Terms:</b>	Net 30	<b>Shipping Method:</b>	Best Way
		<b>Shipping Terms:</b>	F.O.B., Destination	<b>Freight Terms:</b>	

<b>PO</b>	<b>Document</b>	<b>Notifications</b>	<b>Acknowledged Date/Time</b>
-----------	-----------------	----------------------	-------------------------------

**Acknowledgements:** Purchase Order Paper Copy Mailed 09/23/2011 03:15:08 PM

**Master Blanket/Contract Vendor Distributor List**

Vendor ID	Alternative ID	Vendor Name	Preferred Delivery Method	Vendor Distributor Status
<a href="#">000019327</a>	30000003350	Norstar Industries Ltd.	Email	Active

**Master Blanket/Contract Controls**

**Master Blanket/Contract Begin Date:** 04/29/2011 **Master Blanket/Contract End Date:** 08/31/2012  
**Cooperative Purchasing Allowed:** No

Organization	Department	Dollar Limit	Dollars Spent to Date	Minimum Order Amount
AESF - Arizona Exposition & State Fair	44L - Entries - Livestock	\$50,000.00	\$0.00	\$6,025.50

**Item Information**

**Print Sequence # 1.0, Item # 1:** Wood Shavings - medium mixture of screened wood shavings with limited to 3PS - dust free. Shavings to be new product with no sawmill by-products or scrap lumber. (No Cedar). Approx. 3 cu ft minimum, for expanded volume of approximately 9-10 feet. Shavings to be sealed bags, set up on 4'x4' wooden pallets for delivery. Purchases to be conducted by the truckload, delivered count approx 1170 bags

NIGP Code: [325-08](#)  
 Bedding (All Types)

Receipt Method	Qty	Unit Cost	UOM	Discount %	Total Discount Amt.	Tax Rate	Tax Amount	Total Cost
Quantity	1,170.0	\$5.15	EA - Each	0.00	\$0.00		\$0.00	\$6,025.50

Manufacturer: Norstar Industries Brand: Model:  
 Make: Packaging: Bag

Exit

Copyright © 2011 Periscope Holdings, Inc. - All Rights Reserved.

	<b>CONTRACT AMENDMENT</b> Contract No. UM09-003	Arizona Exposition and State Fair Purchasing Office 1826 W McDowell Road Phoenix, Arizona 85007 602-252-6771
	Amendment No 1 (Extension)	

**Contractor:**

Norstar Industries, Ltd.  
 14440 – 124 Avenue  
 Edmonton, AB T5L3B3 Canada

Contact: Meaghan Vinet  
 Tele: 866-464-4252 ext 227

**Wood Shavings**

In accordance with Special Terms and Conditions, "Contract Renewal", the above referenced contract is hereby extended from September 1, 2010 through August 31, 2011.

Renewed contract is for the use and duration of the 2010 Arizona State Fair.

Scheduled work to be amended for new dates – days of week remain the same; product and quantities to remain the same.

**Amended Special Terms –**

A.R.S. § 35-397 prohibits the State and its political subdivisions from purchasing from a company with scrutinized business operations in Iran. By renewing this contract the Contractor is certifying they do not have scrutinized business operations in Iran.

**Amended Special Terms –**

A.R.S. § 35-397 prohibits the State and its political subdivisions from purchasing from a company with scrutinized business operations in Sudan. By renewing this contract the Contractor is certifying they do not have scrutinized business operations in Sudan.

	<b>CONTRACT AMENDMENT</b> Contract No. UM09-003	Arizona Exposition and State Fair Purchasing Office 1826 W McDowell Road Phoenix, Arizona 85007 602-252-6771
	Amendment No 1 (Extension)	

**Amended Special Terms –**

Compliance with Federal Immigration Laws and Regulations.

By entering into the Contract or Contract Renewal, the Contractor warrants compliance with the Federal Immigration and Nationality Act (FINA) and all other Federal immigration laws and regulations related to the immigration status of its employees. The Contractor shall obtain statements from its subcontractors certifying compliance and shall furnish the statements to the Procurement Officer upon request. These warranties shall remain in effect through the term of the Contract. The Contractor and its subcontractors shall also maintain Employment Eligibility Verification forms (I-9) as required by the U.S. Department of Labor's Immigration and Control Act, for all employees performing work under the Contract. I-9 forms are available for download at USCIS.GOV.

The State may request verification of compliance for any Contractor or subcontractor performing work under the Contract. Should the State suspect or find that the Contractor or any of its subcontractors are not in compliance, the State may pursue any and all remedies allowed by law, including, but not limited to: suspension of work, termination of the Contract for default, and suspension and/or debarment of the Contractor. All costs necessary to verify compliance are the responsibility of the Contractor.

All other terms and conditions will remain the same.

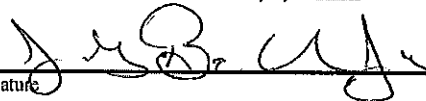
Contractor hereby acknowledges receipt and understanding of the above amendment   Signature _____ Date <u>June 16/2010</u>	The above mentioned contract amendment is hereby executed this <u>16</u> day of <u>JUNE</u> , 2010.   Signature _____  Jack Bell – Executive Consultant Arizona Exposition and State Fair – State of Arizona
_____ Name and title <u>Meaghan Vinet</u>	

	<b>REQUEST FOR QUOTATION</b>	ARIZONA EXPOSITION AND STATE FAIR PURCHASING OFFICE 1826 W. McDowell Road Phoenix, AZ 85007 (602) 252-6771 Ext. 115	
	<b>BID No. UM09-003</b> <b>Title: Wood Shavings</b> <b>Bid Due Date: August 6, 2009 3:00 p.m. MST</b>	Page 1 of 11	DATE: 07/23/09
<b>VENDOR NOTICE</b>			

**THIS IS NOT A PURCHASE ORDER**

Read terms and conditions before preparing your quotation. Vendor should quote his best net price, FOB destination, including all delivery charges, but excluding applicable taxes. Delivery schedule and discount for early payment should be indicated. Return your quotation promptly to the Purchasing Office at the above address, referencing the RFQ number on your sealed return envelope.

In accordance with the A.R.S. §41-2535, competitive bids for the materials, services, or construction specified will be received by the Arizona Exposition and State Fair Purchasing Office at the specified location until the time and date cited above. Bids received by the correct time and date will be opened and the amount bid will be publicly read.

Bids must be in the actual possession of the Arizona Exposition and State Fair Purchasing Office on or prior to the exact time and date indicated above. Late bids will not be considered under any circumstances, except as provided in the Arizona Procurement Code.

Bids must be submitted in a sealed envelope with the Request for Quotation number and the Bidder's name and address clearly indicated on the envelope. All bids must be completed in ink or typewritten using the provided format.

**PURPOSE**

Pursuant to the provisions of the Arizona Procurement code, A.R.S. §41-2501 *et seq.*, The Arizona Exposition and State Fair herein referred to as the agency intends to establish a term contractor for material purchases of wood shavings in accordance with the requirements of this Request for Quotation.

1. This solicitation as a Request for Quotation is being offered as allowed by R2-17-D302.B. Only a small business, as defined in R2-7-101, shall be awarded a contract unless any of the following apply:
  1. The purchase has been unsuccessfully competed under R2-7-D303, including failure to obtain fair and reasonable prices; or
  2. The agency chief procurement officer has made a written determination that restricting the procurement to small business is not practical under the circumstances.
2. A Small Business is one that, including its affiliates, is independently owned and operated, is not dominant in the type of business it conducts, and which employs fewer than 100 full time employees or which has a gross receipts of less than \$4 million in its last fiscal year.
3. This shall not limit competition for individuals or non-small entities who wish to apply.

	<b>OFFER AND ACCEPTANCE</b>	ARIZONA EXPOSITION AND STATE FAIR PURCHASING OFFICE 1826 W. McDowell Road Phoenix, AZ 85007 (602) 252-6771 Ext. 115	
	BID No. UM09-003 Title: Wood Shavings	Page 2 of 11	
<b>VENDOR NOTICE</b>			

**TO THE STATE OF ARIZONA:**

The undersigned hereby offers and agrees to furnish the material, service or construction in compliance with all terms, conditions, specifications and amendments in the Solicitation and any written exceptions in the offer. Signature also certifies Small Business status.

Arizona Transaction (Sales) Privilege Tax License No:

For clarification of this offer, contact:

\_\_\_\_\_

Name: TRICIA DOUGLAS

Federal Employer Identification No:

\_\_\_\_\_

Phone: 866-464-4252, ext 227

NORSTAR SHAVINGS  
Company Name

[Signature]  
Signature of Person Authorized to Sign Offer

14440 - 124 AVENUE  
Address

TRICIA DOUGLAS  
Printed Name

EDMONTON AB T5L3B3  
City State Zip  
CANADA

SALES MGR.  
Title

**CERTIFICATION**

By signature in the offer section above, the bidder certifies:

1. The submission of the offer did not involve collusion or other anti-competitive practices.
2. The bidder shall not discriminate against any employee or applicant for employment in violation of Federal Executive Order 11246, State Executive Order 75.5 or ARS §41-1461 through 1465.
3. The bidder has not given, offered to give, nor intends to give at any time hereafter any economic opportunity, future employment, gift, loan, gratuity, special discount, trip, favor, or service to a public servant in connection with the submitted offer. Failure to provide a valid signature affirming the stipulations required by this clause shall result in rejection of the offer. Signing the offer with a false statement shall void the offer, any resulting contract and may be subject to legal remedies provided by law.
4. The bidder certifies that the above referenced organization is/ is not a small business with less than 100 employees, ~~or has gross revenues of \$4 million or less~~.
5. In accordance with A.R.S. § 35-397, the offeror hereby certifies that the offeror does not have scrutinized business operations in Iran.
6. In accordance with A.R.S. § 35-397, the offeror hereby certifies that the offeror does not have scrutinized business operations in Sudan.

	<b>OFFER AND ACCEPTANCE</b>	ARIZONA EXPOSITION AND STATE FAIR PURCHASING OFFICE 1826 W. McDowell Road Phoenix, AZ 85007 (602) 252-6771 Ext. 115	
	BID No. UM09-003 Title: Wood Shavings		Page 3 of 11
<b>VENDOR NOTICE</b>			

**ACCEPTANCE OF OFFER**

The Offer is hereby accepted.

The contractor is now bound to sell the materials or services listed by the attached contract and based upon the solicitation, including all terms, conditions, specifications, amendments, etc., and the Contractor's Offer as accepted by the State.

This contract shall henceforth be referred to as Contract No. \_\_\_\_\_.  
The Contractor has been cautioned not to commence any billable work or to provide any material or service under this contract until Contractor receives purchase order, contract release document or written notice to proceed.

State of Arizona

Awarded this 1 day of Sept 2009

J Bell  
Procurement Officer - Arizona State Fair

	<b>SPECIAL INSTRUCTIONS</b>	ARIZONA EXPOSITION AND STATE FAIR PURCHASING OFFICE 1826 W. McDowell Road Phoenix, AZ 85007 (602) 252-6771 Ext. 115
	BID No. UM09-003 Title: Wood Shavings	

“Uniform Terms and Conditions” and “Uniform Instructions to Offeror’s” are incorporated by reference. See Enterprise Procurement (EPS) website at [www.azspo.az.gov](http://www.azspo.az.gov). “Procurement Documents”, Version 7.0 and Version 7.1, dated 5-1-03.

#### Confidential Information

If a person believes that any portion of a proposal, bid, offer, specification, protest or correspondence contains information that should be withheld, then the Procurement Officer shall be so advised in writing (Price is not confidential and will not be withheld). Such material shall be identified as confidential wherever it appears. The State, pursuant to A.C.R.R. R2-7-104, shall review all requests for confidentiality and provide a written determination. If the confidential request is denied, such information shall be disclosed as public information, unless the person utilizes the ‘Protest’ provision as noted in §41-2611 through §41-2616.

#### Contract Award

The State intends to award a firm-fixed price contract or contracts, unless otherwise indicated, resulting from this solicitation to the responsible offeror(s) whose proposal represents the best value after evaluation in accordance with the factors and subfactors identified in the solicitation. The State may reject any or all proposals if such action is in the State's best interest. The State may waive informalities and minor irregularities on proposals received. The offeror's initial proposal should contain the offeror's best terms from a price or cost and technical standpoint. The State reserves the right to conduct discussions (negotiations) if the procurement officer determines them to be necessary. If the procurement officer determines that the number of proposals that would otherwise be in the competitive range exceeds the number at which an efficient competition can be conducted, the procurement officer may limit the number of proposals in the competitive range to the greatest number that will permit an efficient competition among the most highly rated proposals. The State reserves the right to make an award on any item for any quantity less than the quantity offered, at unit costs or prices offered, unless the offeror specifies otherwise in the proposal. The State reserves the right to make multiple awards if, after considering the additional administrative costs, it is in the State's best interest to do so. Any exchanges with offerors after receipt of a proposal does not constitute a rejection of counteroffer by the State.

#### Federal Immigration and Nationality Act

By signing the Offer the Offeror warrants that it and all proposed subcontractors are in compliance with the Federal Immigration and Nationality Act (FINA) and all other Federal immigration laws and regulations related to the immigration status of its employees. The Offeror shall obtain statements from all proposed subcontractors certifying compliance with this requirement and shall furnish the statements to the Procurement Officer upon request.

#### Questions

Questions relating to this solicitation shall be directed to the attention of Procurement Officer, Jack Bell, Arizona State Fair, telephone (602) 257-7115. Offerors are encouraged to fax or e-mail questions, no less than seven days prior to the solicitation due date and time, to (602) 271-7115 or [jack.bell@azstatefair.com](mailto:jack.bell@azstatefair.com)

	<b>SPECIAL TERMS AND CONDITIONS</b>	<b>ARIZONA EXPOSITION AND STATE FAIR</b> PURCHASING OFFICE 1826 W. McDowell Road Phoenix, AZ 85007 (602) 252-6771 Ext. 115
	BID No. UM07-006 Title: Wood Shavings	Page 5 of 11

**Authority to Contract**

This contract activity is issued under the authority of the State Procurement Administrator. No alteration of any portion of the contract, any items or services awarded, or any other agreement that is based upon this contract may be made without express written approval of the State Procurement Administrator in the form of an official amendment. Any attempt to alter any documents on the part of any ordering agency or any contractor is a violation of the contract and the Arizona Procurement Code. Any such action is subject to the legal and contractual remedies available to the state inclusive of, but not limited to, contract cancellation, suspension and/or debarment of the contractor.

**Billing**

All billing notices shall include delivery time, and the contractual payment terms. Items are to be identified by the name, model number, contract number, line item number, and serial number if applicable. Any contract release order issued by the requesting agency shall refer to the contract number and line item number(s).

**Contract Cancellation (10 day)**

The state reserves the right to cancel the whole or any part of this contract due to failure by the contractor to carry out any material obligation, term or condition of the contract. The state shall issue written notice to the contractor for acting or failing to act as in any of the following:

The contractor provides material that does not meet the specifications of the contract;

The contractor fails to adequately perform the services set forth in the specifications of the contract;

The contractor fails to complete the work required or furnish the materials require within the time stipulated by the contract;

The contractor fails to make progress in the performance of the contract and/or gives the state reason to believe that the contractor will not or cannot perform to the requirements of the contract.

Upon receipt of the written notice of concern, the contractor shall have ten (10) days to provide a satisfactory response to the state. Failure on the part of the contractor to adequately address all issues of concern may result in the state resorting to any single or combinations of the following remedies.

1. Cancel any contract;
2. Reserve all rights or claims to damage for breach of any covenant of the contract;
3. Perform any test or analysis on materials for compliance with the specifications of the contract. If the result of any test confirms a material no-compliance with the specifications, any reasonable expense of testing shall be borne by the contractor;
4. In case of default, the state reserves the right to purchase materials, or to complete the required work in accordance with the Arizona Procurement Code. The state may recover reasonable excess costs from the contractor by;
  - A. Deduction from an unpaid balance;
  - B. Collection against the bid and/or performance bond; or
  - C. Any combination of the above or any other remedies as provided by law.

**Contract Termination (Convenience)**

Any contract entered into as a result of this solicitation is for the convenience of the State and as such, may be terminated without default by the State by providing a written thirty (30) day notice of termination.

	<b>SPECIAL TERMS AND CONDITIONS</b>	ARIZONA EXPOSITION AND STATE FAIR PURCHASING OFFICE 1826 W. McDowell Road Phoenix, AZ 85007 (602) 252-6771 Ext. 115
	BID No. UM09-003 Title: Wood Shavings	Page 6 of 11

**Current Products**

All products offered in response to this solicitation shall be in current and ongoing production; shall have been formally announced for general marketing purposes; shall be a model or type currently functioning in a user (paying customer) environment and capable of meeting or exceeding all specifications and requirements set forth in this solicitation.

**Contract Type (Term)**

Fixed price term indefinite quantity.

**Delivery**

Delivery shall be made as specified.

**Eligible Agencies (Listed)**

Any contract resulting from this solicitation shall be for the exclusive use of the Arizona Exposition & State Fair.

**Quantities (Considerable and Indefinite)**

The quantities of supplies and services available under the contract are considerable but indefinite.

**Insurance**

The state requires a complete and valid certificate of insurance prior to the commencement of any service or activity specified in this solicitation duration. The insurance company must be currently licensed to transact business in the State of Arizona and rate by Best as an A VII or better. The state will notify the successful contractor of the intent to issue a contract award. The successful contractor must at that time submit an original copy of the attached certificate of insurance, for coverage's in the minimum amounts stated. The coverage's shall be maintained in full force and effect by the contractor during the term of the contract and shall not serve to limit any liabilities or any other contractor obligations.

**Pricing**

Pricing stated shall be F.O.B. Destination. All pricing shall be firm, and include all freight, insurance, warranty costs, and any other applicable costs.

**Packing Slip**

Each shipment shall include a packing slip showing the contract number and the quantity shipped expressed in bags or cubic feet.

**Invoicing**

Separate invoices are required for each shipment of product/service call.

Each separate invoice shall include at a minimum:

- Description and listing of products and quantities
- Date the items were shipped to ASF
- ASF Contract Number & Purchase Order Number
- Price per unit and total per unit
- Applicable Taxes
- Total of invoice

**Price Adjustment (After One Year)**

The Arizona Exposition and State Fair Purchasing Office may review a fully documented request for a price increase only after the contract has been in effect for one (1) year. A price increase adjustment shall only be considered at the time of contract extension and shall be a factor in the extension review process. The Purchasing Office shall determine whether the requested price increase or an alternate option is in the best interest of the State.

**Product Authorized For Sale**

Only products authorized for sale in the United States will be considered acceptable.

	<b>SPECIAL TERMS AND CONDITIONS</b>	ARIZONA EXPOSITION AND STATE FAIR PURCHASING OFFICE 1826 W. McDowell Road Phoenix, AZ 85007 (602) 252-6771 Ext. 115
	BID No. UM09-003 Title: Wood Shavings	Page 7 of 11

**Safety Standards**

All items supplied on this contract must comply with the current applicable occupational safety and health standards of the State of Arizona Industrial Commission, The National Electric Code, and The National Fire Protection Association Standards.

**Term of Contract (1 Year from Award)**

The term of any resultant contract shall commence on the date of the award and shall continue for a period of one (1) year thereafter, unless terminated, cancelled or extended as otherwise provided herein.

**Contract Extension**

This contract may be extended by written amendment for a maximum of forty-eight (48) months. Total aggregate value of the contract shall not exceed fifty thousand (\$50,000) dollars.

	<p>Special Terms and Conditions  <b>Supplemental Information</b>                  Insurance Requirement</p>	<p>ARIZONA EXPOSITION AND STATE FAIR                  PURCHASING OFFICE                  1826 W. McDowell Road                  Phoenix, AZ 85007                  (602) 252-6771 Ext. 115</p>
	<p>BID No. UM09-003                  Title: Wood Shavings</p>	

**INDEMNIFICATION:**

Contractor agrees to indemnify, defend, save and hold harmless the State of Arizona, and their respective directors, officers, officials, agents and employees (hereinafter referred to as "Indemnitee") from and against any and all claims, actions, liabilities, costs, losses, or expenses, including reasonable attorney's fees, (hereinafter collectively referred to as "Claims") arising out of actual or alleged bodily injury or personal injury of any person (including death) or loss or damage to tangible or intangible property caused, or alleged to be caused, in whole or in part, by the negligent or willful acts or omissions of Contractor or any of Contractor's directors, officers, agents, employees, volunteers or subcontractors. This indemnity includes any claim or amount arising or recovered under the Workers' Compensation Law or arising out of the failure of Contractor to conform to any federal, state or local law, statute, ordinance, rule, regulation or court decree. It is the specific intention of the parties that the Indemnitee shall, in all instances, except for Claims arising solely from the negligent or willful acts or omissions of the Indemnitee, be indemnified by Contractor from and against any and all Claims. It is agreed that Contractor will be responsible for primary loss investigation, defense and judgment costs where this indemnification is applicable.

*This indemnity shall not apply if the contractor or sub-contractor(s) is/are an agency, board, commission or university of the State of Arizona.*

**INSURANCE REQUIREMENTS:**

Vendor shall procure and maintain, until all of their obligations, including any warranty periods under this Contract, are satisfied, insurance against claims for injury to persons or damage to property which may arise from or in connection with the purchase and or use of the commodity.

The insurance requirements herein are minimum requirements for this Contract and in no way limit the indemnity covenants contained in this Contract. The State of Arizona in no way warrants that the minimum limits contained herein are sufficient to protect the Vendor from liabilities that might arise out of the purchase and use of the commodities sold under this Contract by the Vendor, his agents, representatives, employees or subcontractors and Vendor is free to purchase such additional insurance as may be determined necessary.

A. **MINIMUM SCOPE AND LIMITS OF INSURANCE:** Contractor shall provide coverage at least as broad and with limits of liability not less than those stated below.

1. **Commercial General Liability - Occurrence Form**  
 Policy shall include bodily injury, property damage, personal injury and broad form contractual liability.
 

• General Aggregate	\$1,000,000
• Products - Completed Operations Aggregate	\$ 500,000
• Personal and Advertising Injury	\$ 500,000
• Fire Legal Liability	\$ 25,000
• Blanket Contractual Liability - Written and Oral	\$ 500,000
• Each Occurrence	\$ 500,000
  
2. **Automobile Liability**  
 Bodily Injury and Property Damage for any owned, hired, and/or non-owned vehicles used in the performance of this Contract.  
 Combined Single Limit (CSL) \$ 500,000
  - a. The policy shall be endorsed to include the following additional insured language: *"The State of Arizona, its departments, agencies, boards, commissions, universities and its officers, officials, agents, and employees shall be named as additional insureds with respect to liability arising out of the activities performed by or on behalf of the Contractor, involving automobiles owned, leased, hired or borrowed by the Contractor."*

	Special Terms and Conditions <b>Supplemental Information</b> <b>Insurance Requirement</b>	ARIZONA EXPOSITION AND STATE FAIR PURCHASING OFFICE 1826 W. McDowell Road Phoenix, AZ 85007 (602) 252-6771 Ext. 115
	BID No. UM09-003 Title: Wood Shavings	Page 9 of 11

**3. Worker's Compensation and Employers' Liability**

Workers' Compensation	Statutory
Employers' Liability	
Each Accident	\$ 100,000
Disease - Each Employee	\$ 100,000
Disease - Policy Limit	\$ 100,000

- a. Policy shall contain a waiver of subrogation against the State of Arizona, its departments, agencies, boards, commissions, universities and its officers, officials, agents, and employees for losses arising from work performed by or on behalf of the Contractor.
- b. This requirement shall not apply to: Separately, EACH contractor or subcontractor exempt under A.R.S. 23-901, AND when such contractor or subcontractor executes the appropriate waiver (Sole Proprietor/Independent Contractor) form.

**B. ADDITIONAL INSURANCE REQUIREMENTS:** The policies are to contain, or be endorsed to contain, the following provisions:

- 1. The State of Arizona, its departments, agencies, boards, commissions, universities and its officers, officials, agents, and employees wherever additional insured status is required such additional insured shall be covered to the full limits of liability purchased by the Contractor, even if those limits of liability are in excess of those required by this Contract.
- 2. The Contractor's insurance coverage shall be primary insurance with respect to all other available sources.
- 3. Coverage provided by the Contractor shall not be limited to the liability assumed under the indemnification provisions of this Contract.

**C. NOTICE OF CANCELLATION:** Each insurance policy required by the insurance provisions of this Contract shall not be suspended, voided, cancelled, reduced in coverage or in limits except after thirty (30) days prior written notice has been given to the State of Arizona. Such notice shall be sent directly to (State of Arizona - Arizona Exposition and State Fair, Attn: Purchasing 1826 W McDowell Road; Phoenix, AZ 85007) and shall be sent by certified mail, return receipt requested.

**D. ACCEPTABILITY OF INSURERS:** Insurance is to be placed with duly licensed or approved non-admitted insurers in the State of Arizona with an "A.M. Best" rating of not less than A- VII. The State of Arizona in no way warrants that the above-required minimum insurer rating is sufficient to protect the Vendor from potential insurer insolvency.

**E. VERIFICATION OF COVERAGE:** Contractor shall furnish the State of Arizona with certificates of insurance (ACORD form or equivalent approved by the State of Arizona) as required by this Contract. The certificates for each insurance policy are to be signed by a person authorized by that insurer to bind coverage on its behalf.

All certificates and endorsements are to be received and approved by the State of Arizona before work commences. Each insurance policy required by this Contract must be in effect at or prior to commencement of work under this Contract and remain in effect for the duration of the project. Failure to maintain the insurance policies as required by this Contract, or to provide evidence of renewal, is a material breach of contract.

All certificates required by this Contract shall be sent directly to (State of Arizona - Arizona Exposition and State Fair, Attn: Purchasing 1826 W McDowell Road; Phoenix, AZ 85007). The State of Arizona project/contract number and project description are to be noted on the certificate of insurance. The State of Arizona reserves the right to require complete, certified copies of all insurance policies required by this Contract at any time. **DO NOT SEND CERTIFICATES OF INSURANCE TO THE STATE OF ARIZONA'S RISK MANAGEMENT SECTION.**

**F. APPROVAL:** Any modification or variation from the insurance requirements in this Contract must have prior approval from the State of Arizona Department of Administration, Risk Management Section, whose decision shall be final. Such action will not require a formal contract amendment, but may be made by administrative action.

**G. EXCEPTIONS:** In the event the Contractor or sub-contractor(s) is/are a public entity, then the Insurance Requirements shall not apply. Such public entity shall provide a Certificate of Self-Insurance. If the contractor or sub-contractor(s) is/are a State of Arizona agency, board, commission, or university then none of the above shall apply.

	<b>Scope of Work / Specifications</b>	<b>ARIZONA EXPOSITION AND STATE FAIR PURCHASING OFFICE 1826 W. McDowell Road Phoenix, AZ 85007 (602) 252-6771 Ext. 115</b>
	BID No. UM09-003 Title: Wood Shavings	Page 10 of 11

**Purpose:**

The Arizona Exposition and State Fair seeks a vendor to provide wood shavings for use in livestock bedding needs at the fairgrounds. The desired quantity is commonly referred to as a "truckload."

**General:**

The following descriptions and quantities are for an estimated purchase. Additional quantities may be needed during the fair. Requested pricing is for both a large single purchase and possible smaller lots that are as needed, if needed.

**Specifications:**

1. Medium mixture of screened wood shavings – limited to dust free.
2. Bagged shavings shall be suitable and intended for use as livestock bedding.
3. Shavings to be new product with no sawmill by-products or scrap lumber. (Wood not to be Cedar).
4. Shavings to be bagged and palletized on 4'x4' wooden pallets. AESF will provide forklift to unload trailer. (pallets not required for single purchases of 10 bags).
5. Bag size – 3.0 cubic feet minimum, for an expanded volume of approximately 9 – 10 cubic feet per bag.
6. Shavings to be packaged in plastic bags with a heat seal or similar closure.
7. Quantity – approximately 960 bags. (commonly termed as truckload).
  - a. Contractor shall identify actual bag count being offered.
  - b. After initial truckload, additional purchases will be done in 10 bag quantities. As needed/if needed.
8. Delivery shall be F.O.B. – Arizona State Fair at 1826 West McDowell Road; Phoenix, Arizona 85007. Must be received by October 2, 2009.

	<h3>Pricing Sheet</h3>	ARIZONA EXPOSITION AND STATE FAIR PURCHASING OFFICE 1826 W. McDowell Road Phoenix, AZ 85007 (602) 252-6771 Ext. 113
	BID No. UM09-003 Title: Wood Shavings	

- Offerors must complete all line items.
- Notice: The State will assume that the price(s) offered do not include any applicable transaction privilege (sales) taxes. If the products and/or services specified require transaction privilege (sales) taxes, they are to be described and itemized separately on the Offer.
- Sales tax percent: \_\_\_\_%. (See Uniform Instructions to Offerors, paragraph 3.11)
- Pricing shall be FOB Destination – Arizona State Fairgrounds 1826 West McDowell Road; Phoenix, Arizona 85007.

Line No	Commodity Description	Qty	U/M	Unit Price	Extended Price
01	Bagged Wood Shavings (as specified). Palletized, 3.0 cubic ft. bag size – expanded volume approx. 9 to 10 cubic feet per bag. (Truckload – estimated count 960).	1040 <del>960</del> Approx.	Ea	5.15	\$5356.00
02	Bagged Wood Shavings (as specified). 3.0 cubic ft. bag size – expanded volume approx. 9 to 10 cubic feet per bag.	10	Ea		

For clarification purposes -

THIS BID/PROPOSAL IS OFFERED BY:

Signature: *Tricia Douglas* Date Aug 5/09

Print Name & Title: TRICIA DOUGLAS, sales mgr.

Name of Company: NORSTAR SHAVINGS

Street or PO Box: 14440-124 AVE.

City/State/Zip Code: EDMONTON, AB T5L 3B3 CANADA

Phone Number: 866-464-4252 ext 227, 780-414-6086 ext 227

Fax No. 780-414-6082

Email Address: tricia@norstarindustries.com